

Tech Line: 1-561-863-2188

LADDER BAR INSTRUCTIONS

Introduction: Congratulations. You have purchased one of the best working, easiest to install and tune drag racing suspension systems available. Properly installed and tuned, your new ladder rear suspension will provide you with years of trouble free, neck wrenching starts with minimum tire spin.

These instructions are just one way of properly installing a ladder bar suspension. Depending on your fabrication experience, you may find it easier or more convenient using other methods that accomplish the same results. Every installation is slightly different and we have attempted to structure these instructions to make your installation as easy as possible.

Part # 3608 (For use with Crossmember Part numbers 3718, 3719 and 3819)

Start your installation by opening all packages and check the parts you have received against the parts list.

Parts list:

- 2... Pro Adjustable Ladder Bars
- 4... Rear End Housing Brackets
- 4... 3/4" x 5/8" Solid Rod Ends
- 2... 3/4" x 3/4" Spherical High Misalignment Rod Ends
- 6... 3/4" Right Hand Jam Nuts
- 2... 3/4" Left Hand Jam Nuts
- 4... 5/8" x 2-1/2" Bolts
- 4... 5/8" Nylock Nuts
- 4... Retaining Straps
- 4... 5/16" Bolts
- 4... 5/16" Nylock Nuts
- 2... Ladder Bar Adjusters

Before starting your installation it is important that the car be in a location where it can remain undisturbed until the job is completed. Any flat surface, such as a garage floor is OK as long as it is flat and level. If you have access to a lift where the car can remain for the duration of the installation, it will make working under the car much easier. For the purpose of this installation, we will be installing the ladder bars on a stock chassis using the existing factory rear end without removing it from the car.

INSTALLATION (on factory chassis and existing rear)

• PREPARING THE CAR

1. Jack the car up to a good working height and place the rear jack stands under the rear end housing instead of the frame rails, so the rear suspension is fully loaded, as if it were sitting on the ground. Place the front jack stands on under the frame rails as far forward as possible. Take time to make sure the car is level from front to rear and side to side.
2. We recommend the removal of the fuel tank, gas lines, brake lines, carpet and interior upholstery in the areas to be

welded, reducing the possibility of fire.

3. Now the centerline of the axle can be found correctly. If, for some reason the rear end housing or car gets moved during installation, you will have these marks to correctly reposition the rear in the car later. Using a carpenters square and plumb bob, mark the rear axle center line on the floor and the fenders for future reference (**See Figure 1**). Begin by placing the square at the front edge of the wheel (rim) and mark the floor (1). Next, place the square at the back edge of the wheel and mark the floor (1). Half the distance between the two is the centerline of the axle (2). Now, hang the plumb bob from the wheel well opening, lining it up with the centerline on the floor. Mark the wheel well opening at this point. Now, you have the centerline of the axle marked on both the floor and the car. Repeat for the other side.

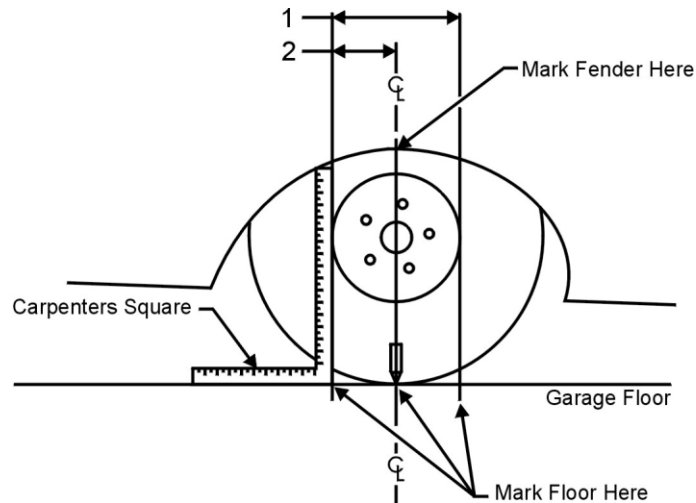

Figure 1

• ASSEMBLING LADDER BARS

1. Begin assembling the ladder bars by threading the 3/4" jam nuts onto the spherical rod ends leaving approximately 3 to 4 threads showing between the end of the jam nut and the ball end of the rod end. Next, thread each rod end into the front ends of each ladder bar until the jam nut touches the ladder bar tube. **DO NOT TIGHTEN.**
2. Install the retaining straps by using (2) 5/16" bolts and nylock nuts. Bolt two of the retaining straps, one strap on either side, to the ladder bar. Tighten the bolts. **See Figure 2.**



Figure 2

3. Start the installation of the adjuster assemblies by threading the 3/4" left hand jam nuts onto the adjusters leaving 3-4 threads between the jam nut and the shoulder of the adjuster. Now, thread the adjusters into the bottom (short side) of each ladder bar until the jam nut stops against the ladder bar tube. **DO NOT TIGHTEN.**

- Next, thread the remaining (4) 3/4" jam nuts onto the solid rod ends, again leaving 3-4 threads between the jam nut and the head of the solid rod end. Thread two of the solid rod end assemblies into the adjuster assemblies until the jam nuts stop against the adjuster. Thread the remaining two into the upper tube of the ladder bars until the jam nuts stop against the ladder bar. **DO NOT TIGHTEN.** See **Figure 3 and 4.**



Figure 3



Figure 4

- Using two of the 5/8" bolts provided in the kit, line up the holes in one of the rear end housing brackets with the solid rod ends at the back of the ladder bar. Make sure that the bolts pass through the solid rod ends and the housing bracket freely. Adjustment of the solid rod ends may be required.
- Place one of the 3/4" bolts from the crossmember kit through the spherical rod end in the front of the ladder bar.
- Place the other housing bracket on top of the first ladder bar. Next, adjust the solid rod ends on the remaining ladder bar to fit over the bolts, including the bolt at the front of the ladder bar in the spherical rod end. This should assure that both ladder bars are adjusted the same. See **Figures 5 and 6.**

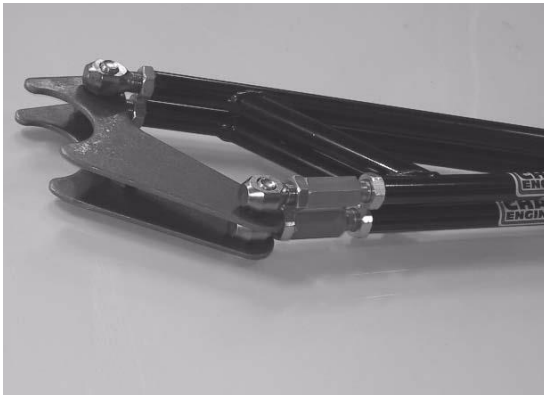

Figure 5



Figure 6

- At this point tighten all of the jam nuts and separate the two ladder bars. With the brackets in place on the first ladder bar, use two of the 5/8" nuts to bolt the assembly together. Assemble the other ladder bar in the same fashion and tighten all bolts.

• LADDER BAR POSITIONING

NOTE: For the purpose of this installation, we will install the ladder bars on a stock chassis using the existing factory rear end without removing it from the car. Leave all factory control arms, springs, etc. in place to hold the rear end in its proper location while installing the ladder bars on the rear end housing and into the car.

1. Take one of the assembled ladder bars and hold it up to the rear end housing, moving it from side to side to determine the best location for mounting. If you will be utilizing the factory leaf or coil springs and shock mounts, your mounting positions may be limited. Ideally, the ladder bars should be positioned as wide as possible without interfering with other components. They must be mounted an equal distance from housing ends on both sides and should not be mounted directly under the frame rails unless there is sufficient room to allow full suspension travel. Some factory brackets may have to be moved at this time to properly mount the ladder bars in the desired locations. **See figure 7.**
2. Now with the mounting locations determined for both sides, prepare the areas for welding. Remove all dirt, paint and oil in the areas to be welded.
3. Reposition the ladder bars on the rear end housing and with the use of zip ties, wire or other devices, temporarily tie the ladder bars to the rear end housing so they will stay in the proper location while fitting the front crossmember. **See Figure 8.**



Figure 7



Figure 8

• CROSSMEMBER POSITIONING

NOTE: Installation of ladder bar crossmembers will have several factors to consider. First, it is strongly recommended and may be necessary to install sub frame connectors on uni-body cars (non-full frame). Crossmembers can be welded to the rocker panels but will require a longer crossmember than provided with the kit. Sub frame connectors stiffen the chassis and provide a place to mount the ladder bar crossmember. Next, is the position of the crossmember, as to how high or low it will be in the frame rails. In some cases the floor may have to be cut to get it in the frame high enough to attain the proper positioning. Occasionally, it may be necessary to mount the crossmember below the frame rails. This can be accomplished by fabricating a mount from box tubing that can be welded to the bottom of the frame. On high horsepower applications, additional bracing is recommended.

4. **Round Tube Crossmember-** Find and mark the center of the dropped section of the crossmember. Slide two of the crossmember brackets over each end of the crossmember. Utilizing the center bolt hole position in the brackets, bolt the crossmember to the front of the ladder bars. Position the crossmember under the car to determine the mounting position and width. Using the centerline mark, the crossmember should be centered directly under the driveshaft. **NOTE:** The distance from the centerline of the axle to the front edge of the crossmember is approximately 37-3/8". **See Figure 9.**
- 4A. **Square Tube Crossmember-** Find and mark the center of the dropped section of the crossmember. Loosely bolt the crossmember brackets, through the center hole, onto both ladder bars (one bracket on each side). Snug the nuts and bolts up enough so they stay in place. Position the ladder bars and crossmember under the car to determine the mounting position and width. Using the centerline mark, the crossmember should be centered directly under the driveshaft. **NOTE:** The distance from the centerline of the axle to the front edge of the crossmember is approximately 37-7/8". **See Figure 10.**

• Proper Position of Crossmember-

NOTE: The height that the crossmember is positioned in the frame rails determines the angle of the ladder bar and greatly determines how effective they are. For the initial set up, we recommend that the front of the ladder bar be slightly lower than the back at an angle of 4-6 degrees. The brackets must be welded with the straight front edge of the bracket vertical (90 degrees from level). The holes in the bracket are radiused so that the ladder bar can be repositioned without affecting the ladder bar adjusters.

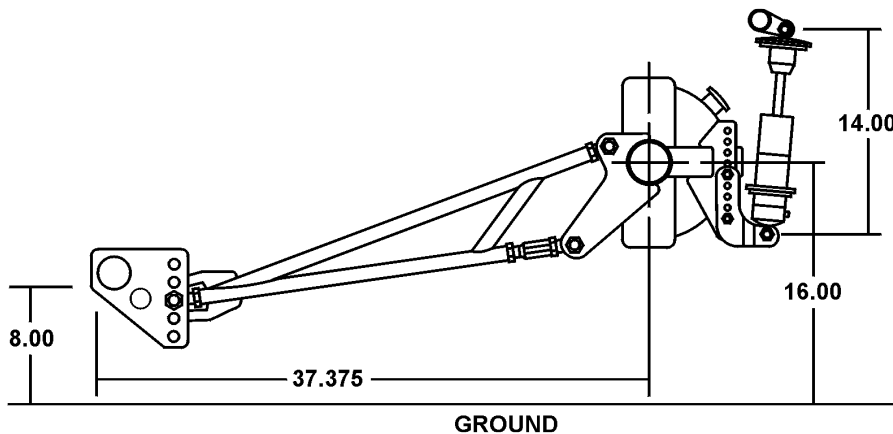

Figure 9

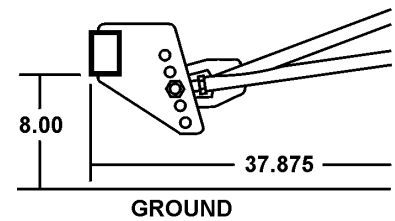

Figure 10

1. Remove the crossmember and cut to the correct length and re-install on the ladder bars. At this point, you should be able to correctly position the entire ladder bar system under the car and tack into place.
2. Double check all dimensions and then tack weld all brackets in place. Be sure to use a tape measure, carpenters square and level to assure the accuracy of the suspension placement.
3. Install rear end locating device, such as a diagonal link, panhard bar or wishbone at this time. See the installation instructions included with the appropriate locating device.
4. Install coil over shocks at this time if applicable. See the installation instructions provided with the coil over shock kit.
5. After making one more check of the position and accuracy of everything installed and tacked into place, prep everything for final welding. To prevent damage from final welding to internal parts of the rear end housing, remove the axles and axle bearings. Make sure all areas for welding are clean and weld small sections at a time and allow them to cool. Excessive heat can cause the rear end housing to warp.

• Removing Factory Components

Now that the ladder bar suspension is installed, there essentially are two suspensions. The factory suspension and the ladder bar suspension. If the factory suspension uses control arms, they MUST be removed. The failure to remove these bars will result in both suspensions binding against each other. Creating a situation where nothing will function as designed. If the car is equipped with leaf springs and there is no intention of converting to coil overs, you must install housing floaters. Housing floaters (part number C/E3740) attach to the rear end housing allowing the housing to slide on the leaf springs. This keeps the rear end housing and ladder bar system to work freely through the travel arc created by the ladder bars. Failure to use housing floaters with leaf spring suspension will cause suspension bind.

• Final Set Up and Tuning

• Pinion Angle

Note: Correct pinion angle is essential for proper ladder bar operation and vibration free, extended U-joint life. Pinion angle should be set at 3-4 degrees lower than the angle of the driveshaft. **See Figure 11.**

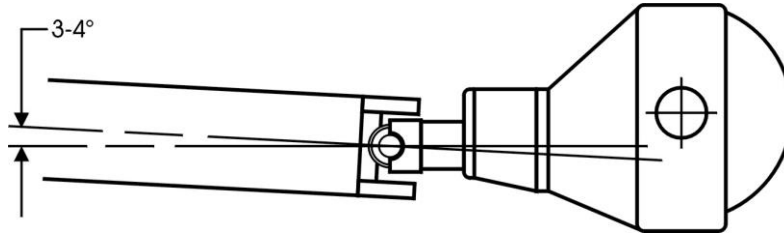

Figure 11

1. Remove the front bolt from the passenger side ladder bar, only.
2. Using the bottom adjuster on the driver side ladder bar, adjust the pinion angle 3-4 degrees below the driveshaft angle.
3. Using the adjuster on the passenger side adjust the ladder bar back up until the bolt goes back into the hole and through the crossmember freely. This ensures that there is no pre-load in the suspension at this time.
4. Tighten all nuts and bolts.

• Tuning The Ladder Bar Suspension

Note: Chassis Engineering ladder bar systems should work correctly “right out of the box” provided that all applicable instructions have been followed. Improvements in reaction times, short times and traction should be dramatic. Very little tuning of the ladder bars is required once the initial set up is established for the car.

We recommend that the car be set up initially with no pre-load in the ladder bars, shocks or springs. If a handling or traction problem exists with a “neutral” set-up, this is an indication that there may be a problem somewhere in the chassis or suspension. Adding pre-load may cure the problem, but it is most likely only masking that problem which may result in another, that could be worse. There are several good drag race chassis set up books available that go into great detail that are highly recommended for fine-tuning.

- Ladder bar adjusters, after initial set up of pinion angle, will allow pre-loading of the rear suspension.